

NS-45/P2 Dual Axis Inclinometer

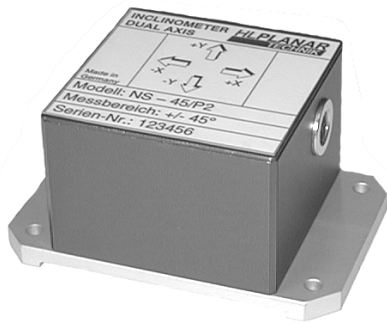

Applications

- Zero point detection
- Aligning and level control
- Angle measurement

Advantages

- Wide range of application
- Low vibration sensitivity
- Higher Precision

The NS-45/P2 dual-axis inclinometer is a member of a family of high performance, competitively priced, single and dual-axis inclinometers. The heart of every HL Planartechnik inclinometer is a small, state-of-the-art, inclination sensor. The sensor, which is comprised of a molded, ceramic case bonded, via a glass sealing process, to a ceramic substrate. Thin film, platinum electrodes are deposited on the substrate. Then the chamber is partially filled with electrolytic fluid and hermetically sealed.

The molded, ceramic, sensor housing combined with a precise, planar electrode geometry yields excellent performance and consistent part-to-part uniformity.

All dual axis P-type inclinometers are microprocessor controlled transducers capable of producing a linearized RS-232 digital output. With their machined, aluminum baseplate and IP 65 housing, they are an ideal choice for a variety of industrial, automotive and aerospace applications.

Pinout

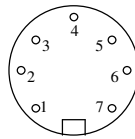

1	+Ub	Supply Voltage
2	GND	Ground
3	Earth	Earth
4	n.c.	n.c.
5	n.c.	n.c.
6	Input digital RS232	RxD
7	Output digital RS232	TxD

Specifications

Range:	$\pm 45^\circ$
Precision: digital:	$\pm 0.05^\circ$
Resolution:	0.003°
Temperature stability: Zero point: Sensitivity (up to $\pm 30^\circ$):	$< 2 \cdot 10^{-3} \%K$ $< 5 \cdot 10^{-3} \%K$
Output signal: Digital RS 232	In degrees
Transmission rate:	2400 or 9600 Baud
Format:	ASCII
Operating temp. Range:	$-25^\circ C \dots +85^\circ C$
Storage temp. Range:	$-40^\circ C \dots +85^\circ C$
Supply voltage:	$+ 7 \dots + 24VDC$
Current consumption:	ca. 35 mA
Protection class:	IP 65
Connection:	Connector or Pigtail

Dimensions (mm)

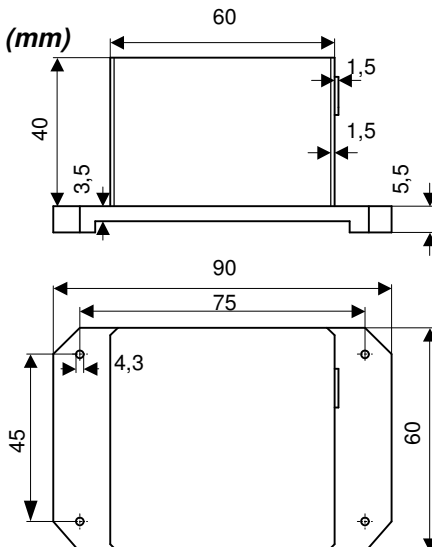

HL-Planartechnik GmbH

Hauert 13, D - 44 227 Dortmund, Tel.: +49 (0) 231/97400, Fax.: +49 (0) 231/974020

Internet: <http://www.hlplanar.com> E-Mail: service@hlplanar.de