

DESCRIPTION

Standard liquid level sensor. The sensor has to be mounted vertically for best results.

Two versions are available:

PP (Polypropylene) for water applications and dilute acids

PA (Polyamide) for use in oil, gasoline (petrol) and brake fluid

The standard termination is a PVC cable with a cross section of 0.14 mm² and a length of 500 mm. The cable can be modified on request.



APPLICATIONS

- Liquid container monitoring in household appliances, automotive applications, test and measurement, and control technology.

DIMENSIONS

All dimensions in mm [inches]

FEATURES

- High power switches available
- Other cables, connectors and colors available
- Form A (normally open) and Form B (normally closed) types are available

MATERIALS

Materials PA version	
Shaft, nut	Polyamide black
Float	Polyamide natural white
Seal	Nitrile rubber
Materials PP version	
Shaft, nut	Polypropylene white
Float	Polypropylene natural white
Seal	Nitrile rubber

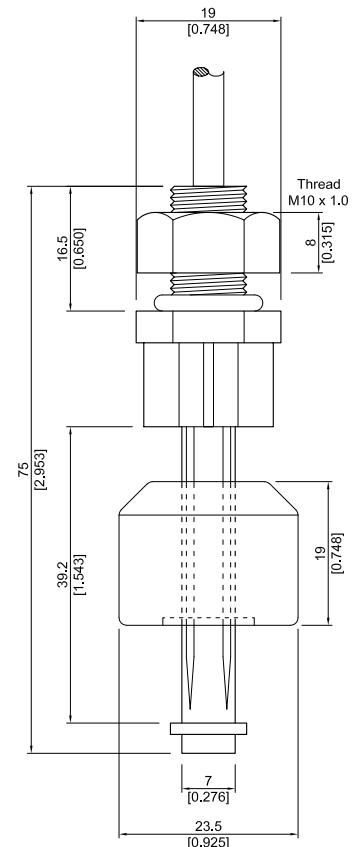

Level Sensors with
Magnetic Floats

MOVEMENT

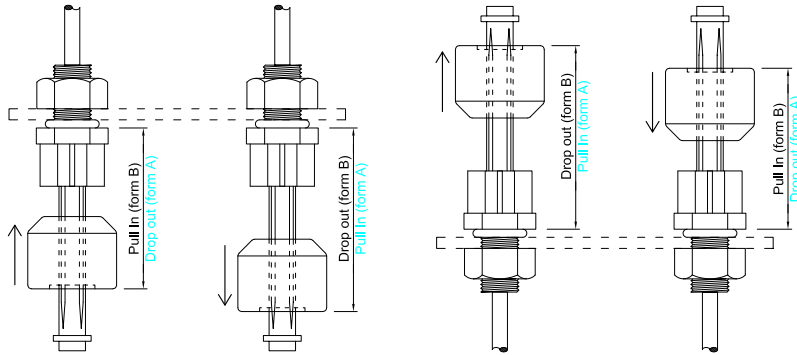

ORDER INFORMATION

SERIES	CONTACT FORM	SWITCH MODEL	MATERIAL	CABLE LENGTH (mm)	TERMINATION
LS02 -	XX	XX -	XX -	XXX	X
OPTIONS	1 Form A 1 Form B	71, 84	PA, PP	500 *	W, X, Y
* Other cable lengths available.					

Part Number Example

LSO2 - 1A71 - PA - 500 W

1A is the contact form
71 is the switch model
PA is the material
500 is the cable length (mm)
W is the termination

TERMINATION

For wire and termination details please consult factory.

W		The cable cut length includes: 30 mm of separated wire with 5mm of wire stripped and tinned
X		The cable cut length includes: 30 mm of separated wire with individual crimped terminals
Y		The cable cut length includes: 30 mm of separated wire with individual spade terminals

CONTACT DATA

All data 20 °C	Switch Model --> Contact Form -->	Contact 71 Form A / B			Contact 84 Form A / B			Units
		Min.	Typ.	Max.	Min.	Typ.	Max.	
Contact Ratings	Conditions							
Contact Rating	Any DC combination of V & A not to exceed their individual max.'s			10			10	W
Switching Voltage	DC or peak AC			200			400	V
Switching Current	DC or peak AC			0.5			0.5	A
Carry Current	DC or peak AC			1.25			1.0	A
Static Contact Resistance	w/ 0.5V & 10mA			150			150	mΩ
Dynamic Contact Resistance	Measured w/ 0.5V & 50mA 1.5 ms after closure			200			200	mΩ
Insulation Resistance across Contacts	100 Volts applied	10 ¹⁰ *			10 ¹¹			Ω
Breakdown Voltage across Contacts	Voltage applied for 60 sec. min.	225 *			700			VDC
Operate Time, incl. Bounce	Measured w/ 50% overdrive			0.5			2.0	ms
Release Time	Measured w/ no coil suppression			0.1			0.1	ms
Capacitance	@ 10kHz across contact		0.2			0.7		pF
Environmental Data								
Shock Resistance	1/2 sine wave duration 11ms			50			50	g
Vibration Resistance	From 10 - 2000 Hz			20			20	g
Ambient Temperature	10 °C/ minute max .allowable	-20		90	-20		90	°C
Storage Temperature	10 °C/ minute max. allowable	-20		100	-20		100	°C
Soldering Temperature	5 sec dwell			260			260	°C
Please note: The indicated electrical data are maximum values and can vary downwards when using a more sensitive switch. * Insulation resistance of 10 ¹² and breakdown voltage of 480 VDC is available. These ranges refer to the uncut / unmodified Reed Switches described in our Reed Switch section. Consult factory if more detail is required.								